

Cooling slope casting to obtain thixotropic feedstock I: observations with a transparent analogue

E. Cardoso Legoretta · H. V. Atkinson ·
H. Jones

Received: 27 November 2007 / Accepted: 24 June 2008 / Published online: 16 July 2008
© Springer Science+Business Media, LLC 2008

Abstract New Rheocasting (the NRC process) is a recently developed semisolid processing route. There are two versions of this route. In one, molten alloy is poured directly into a tilted mould and through careful temperature control during cooling a spheroidal semisolid microstructure is achieved, before the material in the mould is upended into a shot sleeve and hence forced into a die. Alternatively, the molten alloy is poured onto a *cooling slope* and thence into a mould before processing. The aim of the work described in this article, and its companion, was to develop understanding of the microstructural development during the initial stages of this process i.e. in the mould before processing and with the cooling slope/mould combination. In this first article, an analogue system based on aqueous ammonium chloride has been used to visualise what happens when an alloy is poured into a tilted mould with a chill wall. In the companion article, the results for pouring A356 aluminium alloy directly into a mould, and also via a cooling slope into a mould are presented.

Introduction

In the early 1970s, a group at MIT discovered that when a solidifying alloy was continuously stirred the viscosity fell to a much lower value than for the static case [1]. This was associated with the fact that, during stirring in the semi-solid range, the dendritic microstructure was destroyed and the semisolid consisted of spheroids of solid in a liquid matrix. In this state, the material behaved thixotropically i.e. when sheared it flowed but when allowed to stand it thickened again; the viscosity was a function both of time at temperature and of shear rate. The behaviour was associated with the dynamic development of microscopic ‘welds’ between solid spheroids (agglomeration) and the break up of these welds under shear (disagglomeration) [2]. It became the basis of a new range of forming technologies termed collectively *semisolid processing*. The advantages over conventional die casting including less mould attrition, reduced porosity and hence higher part integrity, and near net shape (because there is less solidification shrinkage). A range of reviews are available [2–6].

There are various types of semisolid processing: ‘Rheocasting’ refers to the process where the alloy is cooled into the semisolid state and injected into a die without an intermediate solidification step; ‘Rheomoulding’ is allied to polymer injection moulding, and uses either a single screw or a twin screw. ‘Thixo’ usually refers to processes where an intermediate solidification step does occur. (There are exceptions to this e.g. ‘Thixomolding[®]’, which is used to produce magnesium alloy components, e.g. for portable computers and cameras). ‘Thixofforming’ can cover both ‘thixocasting’, ‘thixoforging’ and an intermediate process called ‘thixofforming’. Thixocasting tends to take place with relatively high fractions of liquid and thixoforging when the fractions are lower. Thixocasting

E. Cardoso Legoretta
Universidad Autónoma del Estado de Hidalgo, Centro
de Investigaciones en Materiales y Metalurgia, Ciudad
Universitaria, Carretera Pachuca-Tulancingo Km. 4.5,
Pachuca, Hidalgo, Mexico

E. Cardoso Legoretta · H. Jones
Department of Engineering Materials, University of Sheffield,
Sir Robert Hadfield Building, Mappin Street, Sheffield S1 3JD,
UK

H. V. Atkinson (✉)
Department of Engineering, University of Leicester, University
Road, Leicester LE1 7RH, UK
e-mail: hva2@le.ac.uk

involves placing the slug of semisolid material in a shot sleeve and injecting into a die. In thixoforging, the slug of semisolid material is placed between dies and the die halves brought together around the slug. In all cases, thixotropic feedstock is required.

There is a constant drive to move to the ‘Rheo’ forms of the process because this eliminates the intermediate solidification step and hence reduces cost. The non-dendritic feedstock microstructure can be obtained by a variety of means during cooling including mechanical stirring or electromagnetic stirring in the shot sleeve as in the New SemiSolid Metal Casting process from Hitachi [7]. Alternatively, the New RheoCasting (NRC) process (Fig. 1) patented by UBE [8, 9] involves stimulating nucleation of solid particles. Molten alloy is poured, at a temperature slightly above the liquidus, into a tilted steel crucible. In one version of the route this pouring is via a *cooling slope* (Fig. 1 step [1]-a) and in the other the pouring is direct (Fig. 1 step [1]-b). The alloy is then partially solidified in the mould under controlled cooling conditions, which includes the application of heat to the mould using an induction heater (stage [3] in Fig. 1). This results in a spheroidal microstructure in the semisolid state. The temperature is equalised across the cross-section of the mould and the semisolid slug is then upended into the shot sleeve (hence leaving any oxide skin in the discard) and injected into the die to produce the component. There is no need for specially treated thixoformable feedstock and scrap can be readily recycled within the plant (as opposed to conventional thixoforming where the scrap must be returned to the supplier of the feedstock to be retreated e.g. with the Magneto-Hydro-Dynamic (MHD) process). Hall et al. [9] showed that the NRC route has a lower unit cost than thixoforming, due to the lower starting material cost. The

principal disadvantage is that the process is relatively inflexible, with the mould size and mould induction heating conditions very precisely related to the metered volume of alloy. Thus, the process is highly suitable for volume production of a particular component where no change in the metered volume is required. It is less suitable for producing components of varying sizes where, each time the size changed, a different mould would be required. The NRC process is gaining increasing industrial attention for high-volume component production.

Kaufmann et al. [10] compared NRC material with that produced by a conventional commercial thixocasting process and found a higher degree of compositional homogeneity and overall globule spheroidicity. It was also shown [11] that for high quality slugs, it is important to hold the melt close to the liquidus temperature and to quench it quickly to form many nuclei. These are distributed throughout the cup and grow in a globular fashion when two criteria are both fulfilled—the size of the nuclei and the temperature gradient in the cup must both be small. Dendritic growth is then suppressed. Uggowitzner and Kaufmann [12] argued that the nuclei are formed by ‘forced homogeneous nucleation’ due to partial quenching of the melt. This was backed up by simulation results from Zhu et al. [13]. Further detail will be given of work in the literature using a cooling slope in the Introduction to the companion article. Here the background on analogue systems is outlined since that is the principal concern of this first article.

Semitransparent analogue systems have been used for research into metal solidification because they allow visualisation [14]. The most common analogue system used in laboratory experiments (and in the present work) is aqueous ammonium chloride ($\text{NH}_4\text{Cl}-\text{H}_2\text{O}$) with NH_4Cl concentration between 25 and 40wt.%. Jackson et al. [14]

Fig. 1 Schematic illustration of the NRC process [8]. Step [1] is the holding furnace with pouring into a tilted mould via either a cooling slope ([1]-a) or directly ([1]-b). In step [2] the mould is brought up to vertical. In step [3] controlled cooling is taking place, with some heat input from an induction heater. The material is in the semisolid state with a gradual increase in solid content. In step [3]-c, the mould is upended so that the semisolid material moves into a shot sleeve. In step [4], the material is injected into a die

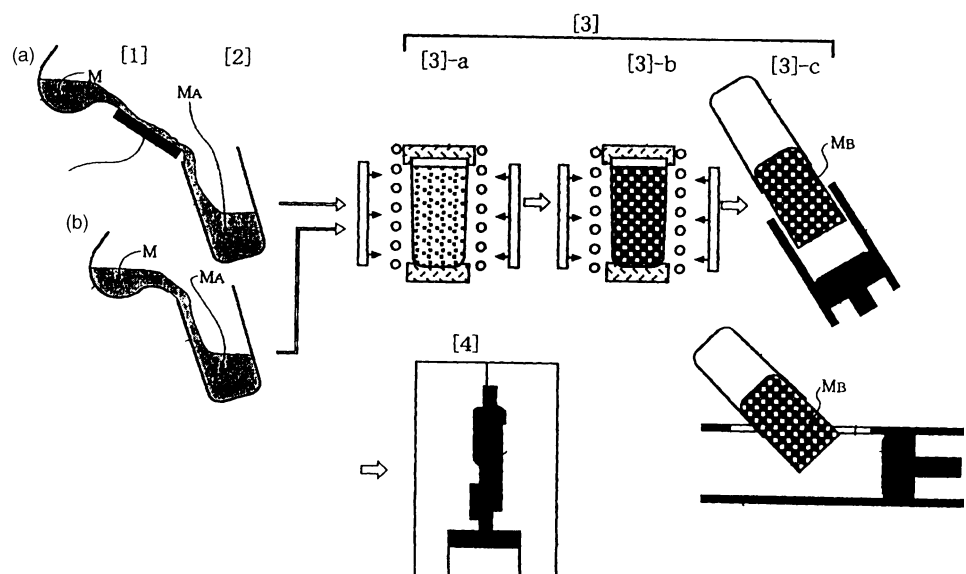

studied the origin of the grains that comprise the equiaxed region in a conventional casting. When the solution was poured at temperatures close to the saturation temperature, crystals appeared throughout the liquid and swirled in a snow storm effect ('big-bang nucleation'). They concluded that, under the interaction of heat and matter fluxes during dendritic growth, the partial remelting of dendrites is an important mechanism for producing the equiaxed region. Beckerman and Wang [15] noted that thermal and solute buoyancy forces cause convection in the melt and observed nucleation, fragmentation, recalescence, multicellular thermosolutal convection and sedimentation of NH_4Cl crystals. They used a square cavity evenly cooled from the sidewalls. In the initial stages of the experiment, a large number of free crystals were observed in the upper portion of the melt. These originated from fragmentation of the crystals at the walls, which were ejected into the bulk melt by the convective flow in the residual solution.

Several authors have investigated the effect of the flow behaviour on the solidification process using analogue systems [16–20]. Paradies et al. [19] showed that an imposed velocity in the melt dramatically changed the rate and total amount of crystal fragmentation developed. In other work with succinonitrile/acetone [21], it was found that increasing the velocity of forced flow in a tube increases the rate of recalescence but the largest cumulative total of fragments was produced with an intermediate rate of flow. Mullis et al. [22] examined the formation of spheroidal microstructures for semisolid processing with a glass vessel and made observations as a function of cooling rate. They observed large dendritic crystals at a high cooling rate, but even at the lowest cooling rate employed,

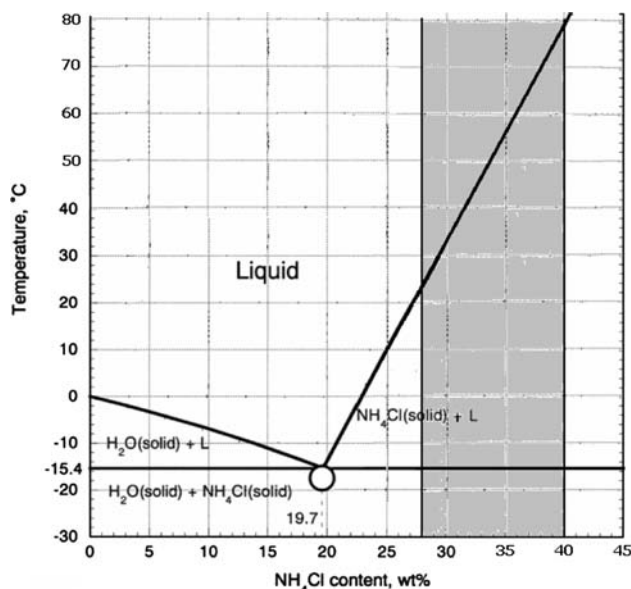

Fig. 2 H_2O – NH_4Cl phase diagram. Shaded region is the composition range of interest in the present work (adapted from [23])

no evidence of the rosette or spheroidal structures characteristic of metallic systems solidified under applied shear was found.

The distinctive feature of the work described here is that the vessel is tilted with the lower side wall subject to cooling. This mimics the arrangement in Fig. 1 Step [1] (b) where the melt is poured directly into the tilted mould. It also provides some insight into microstructural development with the cooling slope (Fig. 1 Step [1] (a)) during the initial stages of pouring into the tilted vessel. The aim is to draw out the observations which are relevant to the NRC process.

Experimental method

Ammonium chloride of ACS grade (99.5%) was used. A partial phase diagram is shown in Fig. 2 with relevant

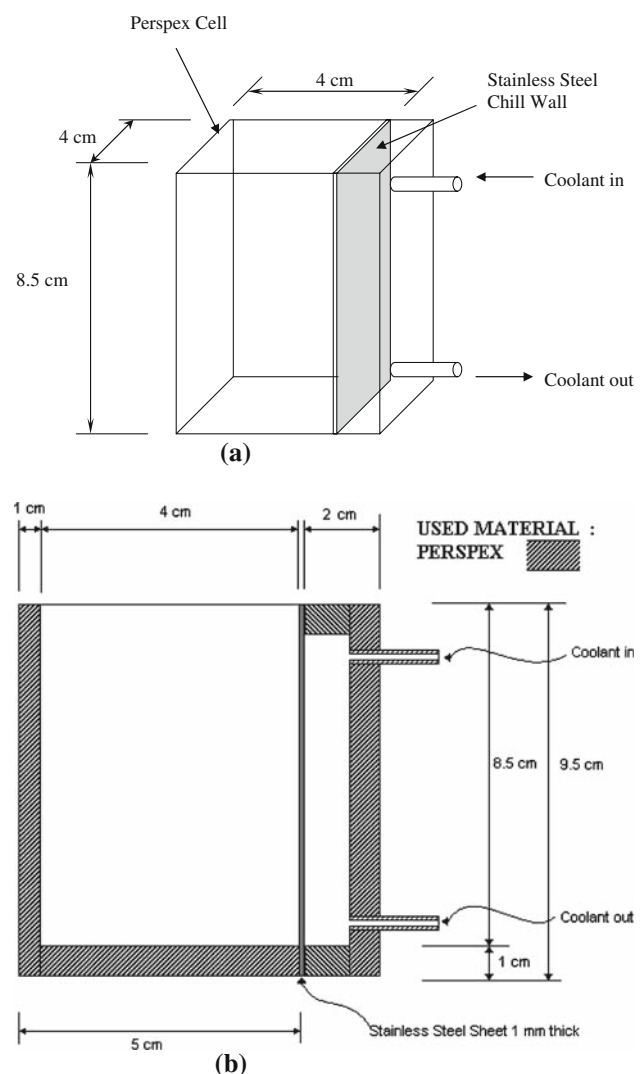

Fig. 3 Perspex cell used for analogue studies with the NH_4Cl – H_2O system. (a) 3D representation, (b) Cross section of the test cell

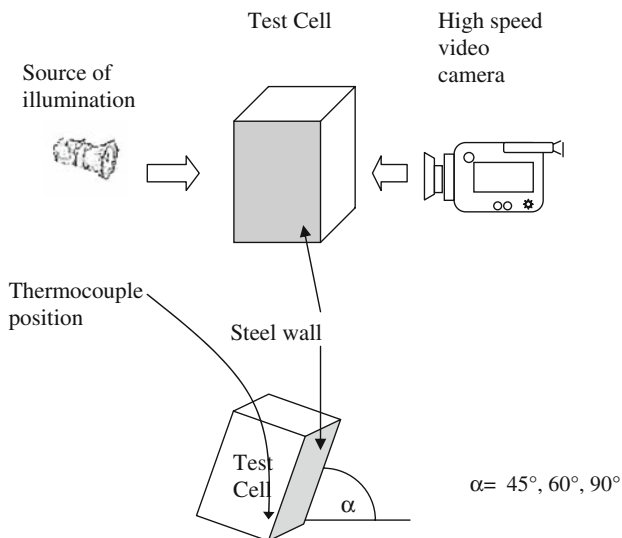

Fig. 4 Set-up for the analogue system experiments

compositions. Experiments were performed with solution concentrations of 28, 30, 35 and 40wt.% NH_4Cl with liquidus temperatures of 22, 31, 55 and 78 °C, respectively. The total volume of solution was kept at 100 ml for all concentrations.

The perspex test cell is shown in Fig. 3, and incorporates a stainless steel chill wall polished to a 1- μm diamond finish. The wall was cooled with circulating cold water to between 14 and 16 °C i.e. about 30 °C above the eutectic temperature of -15.4 °C. Crystallisation was filmed with a high-speed JVC video camera. In the first set of experiments, in order to monitor the temperature, a K-type thermocouple was located at the bottom of the test cell (Fig. 4). The tilt angles used for experiments are shown in Fig. 4.

The procedure to carry out the experiments was as follows. 100 ml of solution containing 28, 30, 35 or 40wt.% NH_4Cl in water was first prepared in a beaker. This was heated and stirred on a hot plate and the temperature checked with a thermometer. The heating was continued until all the crystals had dissolved and the solution had reached the desired temperature. This temperature was maintained for 5 more minutes. Meanwhile the water flow had been circulating through the back of the chill wall in the test cell for at least 10 min. The solution was then poured into the transparent cell down the wall. Results for the tilted cell are compared with those where the chill wall is vertical. The experimental conditions are shown in Table 1.

Experimental results

Typical results for the tilted wall are shown in Figs. 5 and 6. Once the solution was poured into the test cell, the

Table 1 Conditions for the experiments with $\text{NH}_4\text{Cl-H}_2\text{O}$

Experiment number	Solution concentration (NH_4Cl wt.%)	Pouring temperature °C	Tilt angle α (°)
1	28	36	60
2	28	36	45
3	28	28	45
4	30	54	45
5	30	49	45
6	30	44	45
7	30	39	60
8	35	70	60
9	35	65	45
10	35	60	60
11	40	100	45
12	40	90	60
13	30	39	90
14	35	56	90
15	35	60	90
16	35	70	90
17	35	65	60
18	35	65	45
19	40	90	60
20	40	100	45

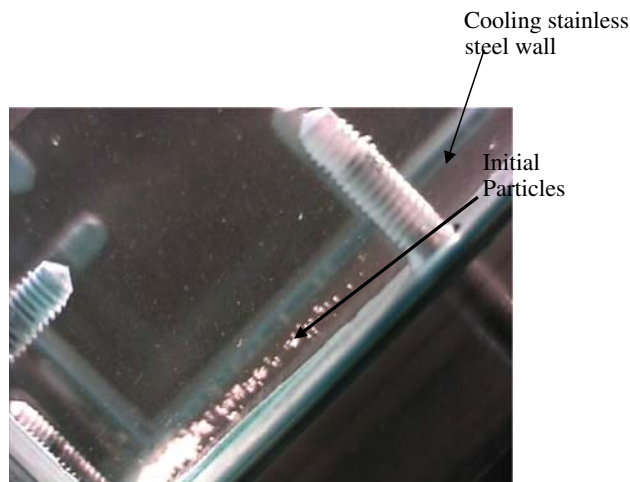

Fig. 5 Initial growth of the NH_4Cl crystals on the cooling wall at 45° tilt, 10 s of the process, 35% NH_4Cl . Superheat 10 K

crystallisation process started at the chill wall. Nuclei formed on the stainless steel plate with no discernible pattern and no apparent preferential nucleation (e.g. on residual scratches). Small particles formed on the wall and then rolled down the wall towards the bottom.

Videosequences are available on application to the corresponding author. Examining the behaviour with a relatively high superheat (13 K, 30wt.% NH_4Cl , tilt angle 45°) shows that particles are of various sizes when they

Fig. 6 Initial growth of the NH_4Cl crystals on the cooling wall, 30% NH_4Cl , superheat 10 K. (a) 60° tilt, (b) 45° tilt

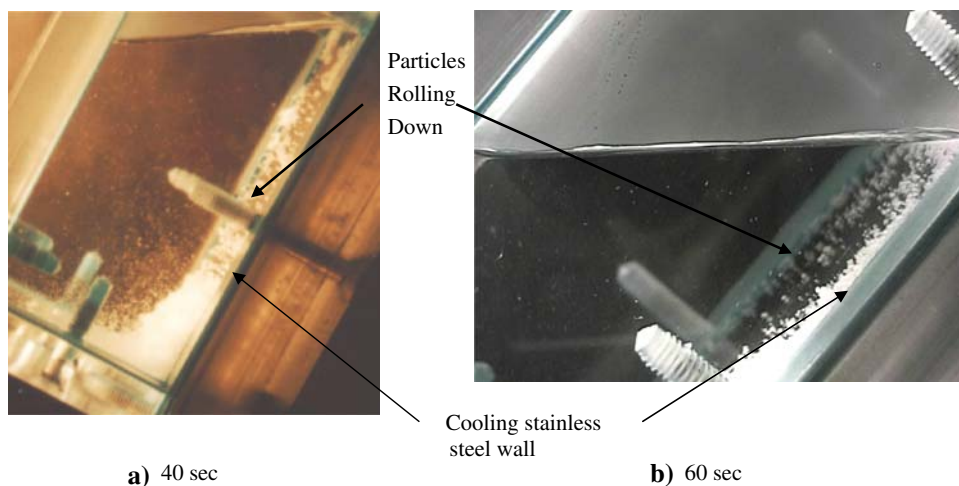

Fig. 7 Nucleation and growth from the ammonium chloride solution on the cooling wall (35wt.% NH_4Cl poured at 65 °C, superheat 10 K, tilt angle $\alpha = 45^\circ$)



start to roll. The time of residence on the chill wall therefore depends not only on size and therefore flow forces must be operating as well as gravitational forces. Comparing results for 45° and 60° tilt angles (35% NH_4Cl solution, 10 K superheat—see Figs. 7 and 8) shows that, with the 45° tilt angle, as expected, the initial particles rolled down more slowly than with the higher tilt angle. Columnar dendritic growth on the chill wall was therefore

more evident for the 45° results (note that this can be seen by eye but is not visible in the figure because of the video resolution). Columnar dendrites tended to develop after the first 40 s or so.

Low superheat leads to copious nucleation (Fig. 9) with small particles on both the chill wall and nucleating in the bulk solution. Over time these initial crystals settle and dendritic growth develops. The higher initial NH_4Cl

Fig. 8 Nucleation and growth from the ammonium chloride solution on the cooling wall (35wt.% NH₄Cl poured at 65 °C, superheat 10 K, tilt angle $\alpha = 60^\circ$)

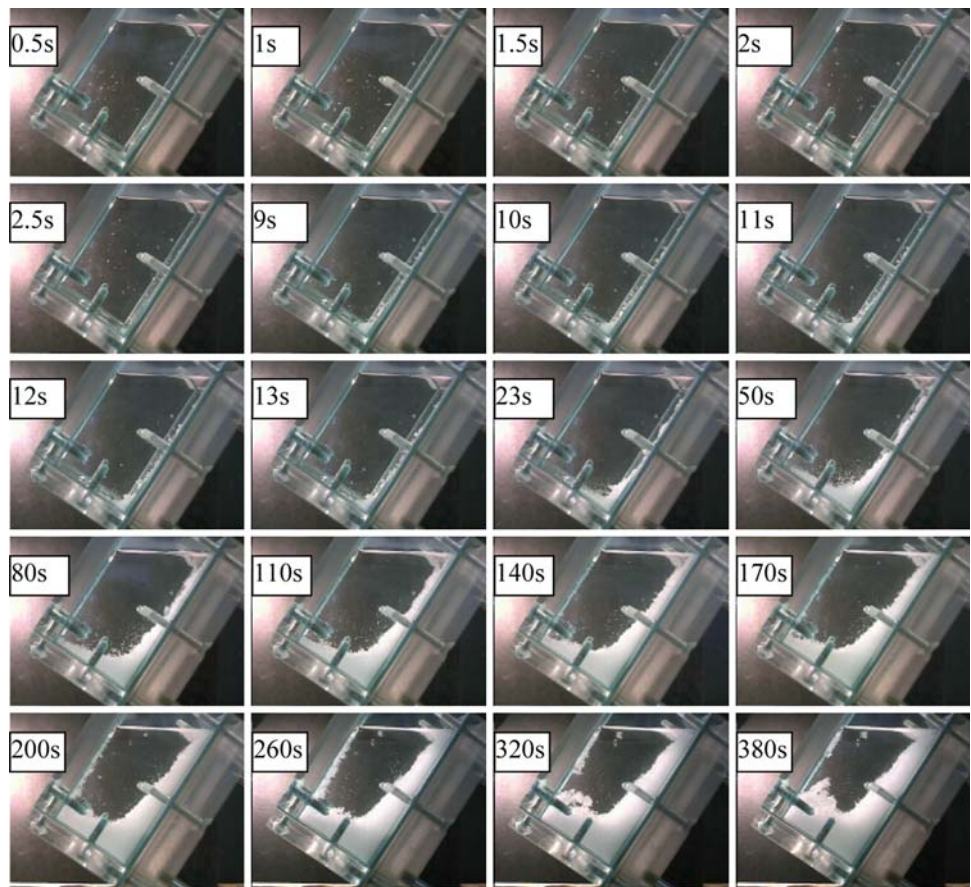
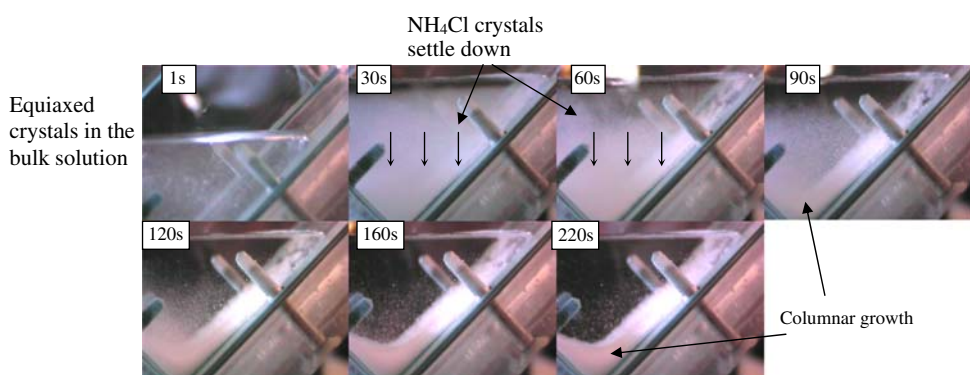

Fig. 9 Copious nucleation in the NH₄Cl–H₂O system (28wt% NH₄Cl, superheat 6 K, tilt angle $\alpha = 45^\circ$)



concentrations (35 and 40wt.%) also give more copious nucleation than the lower concentrations.

In experiments with a vertical chill wall (Fig. 10), the numbers of nuclei in the bulk quickly increase in the first stages. Some of these appear to have originated in the bulk and some from fragmentation of crystals at the wall. Crystals tend to congregate in the upper portion of the melt during the first 5 min and then descend slowly, becoming entrained in the thermally driven downward flow of fluid adjacent to the crystallisation front. Some of the crystals become lodged in the liquidus front of the mushy zone

(Fig. 10b). Crystals rotating in the flow in the bulk tend to show a symmetrical dendritic morphology whilst those attached to the cooling slope are columnar. Comparing results for the vertical chill wall with those for the tilted wall, the cooling wall is more effective in promoting crystallisation in the latter case, the high concentration of fine crystals formed during initial contact with the mould wall becoming redistributed through the liquid. This effect is counteracted if the superheat is too high (say 15 K) because the crystallites tend to redissolve when they move out into the bulk solution.

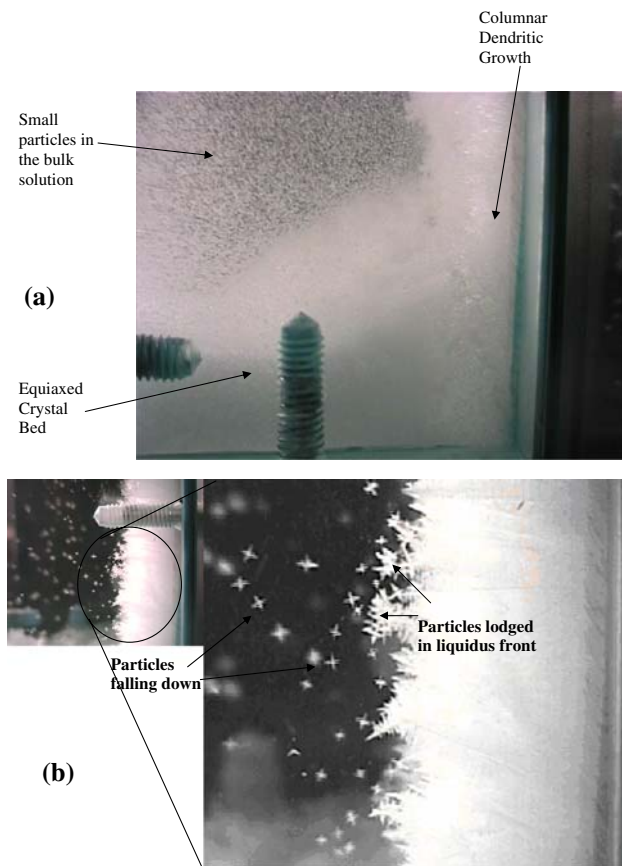

Fig. 10 Columnar growth and mushy equiaxed crystal bed at (a) the beginning of the process and (b) middle of the experiment showing columnar and equiaxed NH_4Cl crystals. (35wt.% NH_4Cl , superheat 5 K, tilt angle $\alpha = 90^\circ$)

Discussion

The essential aim of the NRC process is to obtain a spheroidal morphology uniformly across the casting, albeit after a process of equilibration (Fig. 1 steps [3]-a and [3]-b) where heat is transferred whilst the mould is being held in the semisolid state in a vertical position. Here the experiments focus on the initial stages of the process, rather than the equilibration (i.e. Fig. 1 stages [1] and [2]). In addition, in the aqueous ammonium chloride system there is a substantial density difference between the crystals and the liquid, giving rise to settling, which does not exist to the same extent for solidification in aluminium alloys. Given these provisos, the following points can be made:

(1) The higher initial NH_4Cl concentrations (35 and 40wt.%) and lower superheats (1–5 K) tend to give more copious nucleation, as would be expected (schematically shown in Fig. 11a). Low superheat enhances crystal survival, partly through a reduction in thermal convection. The superheat results are significant

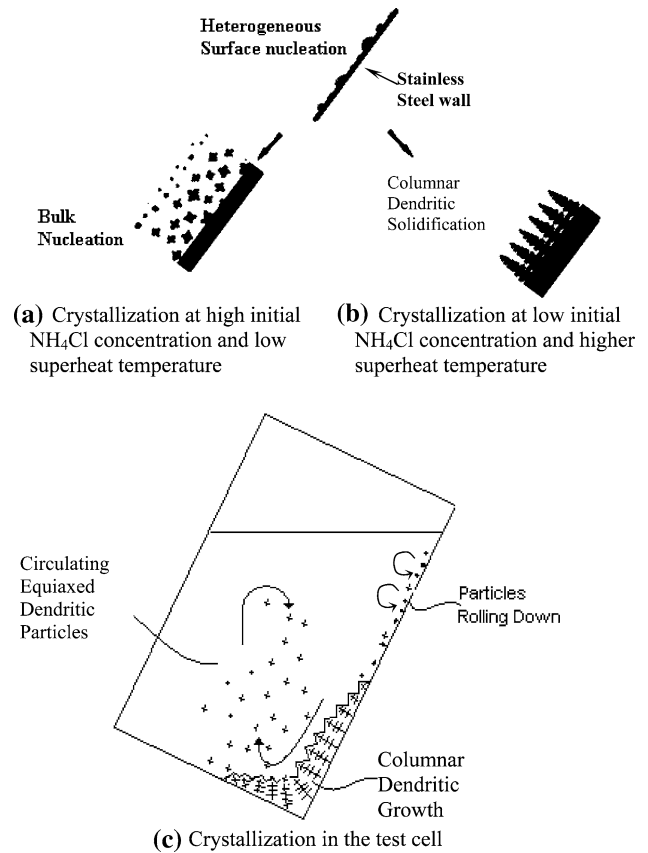

Fig. 11 (a) Equiaxed solidification due to bulk nucleation in the solution and heterogeneous surface nucleation; (b) Columnar dendritic solidification, (c) Schematic diagram of phenomena in the early stage of crystallisation of the ammonium chloride solution. (a) and (b) adapted from [24]

for the NRC process. Lower initial concentrations and higher superheats tend to produce gradual columnar dendritic solidification (schematically shown in Fig. 11b and c).

- (2) Crystals nucleating on the chill wall are observed to roll down the wall after a certain residence time. This raises the interesting issue as to the importance of the surface finish on the chill wall. This should not occur to the same extent in the NRC case where there is little density difference between the crystal and the liquid. However, the surface finish of the chilling surface will play an important role in determining how easy it is for crystals to become detached from the chill wall and incorporated into the fluid flow.
- (3) Increasing tilt angle from 45° to 60° tends to increase the speed at which particles roll down the wall and therefore enhance the possibility of equiaxed formation rather than columnar dendritic growth. This again has important implications for the NRC process, either in terms of the tilt of the mould (for direct

pouring) or the tilt of the cooling slope. However, there will be an optimum angle for enhancing equiaxed formation beyond which the chill wall is not able to play as significant a role in nucleation.

The observations on the morphology of the crystals in the bulk are consistent with work by Appolaire et al. [25] who showed that crystals rotating in the flow tend to be symmetrical, whilst those which are not become asymmetrical.

In a companion article [26], the results for pouring A356 aluminium alloy directly into a mould, and also via a cooling slope into a mould, are presented. The observations with the transparent analogue provide insight into the phenomena which are occurring.

Summary and concluding remarks

The aim here was to visualise the initial stages of the solidification processes in NRC with aluminium alloys through the use of a transparent aqueous ammonium chloride analogue. The ammonium chloride has been poured into a perspex cell with one wall chilled. This mimics the mould and the cooling slope in the NRC process, although there is a substantial density difference between the crystals and the remaining liquid in the ammonium chloride system which leads to some settling which does not occur with aluminium alloys. Higher initial NH₄Cl concentrations (35wt.% and 40wt.%) and lower superheats (1–5 K) tend to give more copious nucleation, as would be expected. The superheat results are significant for the NRC process. Crystals nucleating on the chill wall roll down the wall after a certain residence time. The surface finish of the chill wall (cooling slope) may therefore be important in determining how easy it is for crystals to become detached from the chill wall and incorporated into the fluid flow. Increasing the tilt angle (up to a point beyond which the chill wall is not able to play a full role in enhancing nucleation) tends to increase the speed at which particles roll down the wall and therefore to enhance the possibility of equiaxed formation rather than columnar dendritic growth. A companion article gives results for pouring A356 aluminium alloy directly into a mould and also into a mould via a cooling slope.

Acknowledgements E. Cardoso Legoretta would like to acknowledge the financial support provided by CONACyt and SEP and also the Universidad Autónoma del Estado de Hidalgo for support. The authors are grateful to the Department of Engineering Materials at the University of Sheffield for the provision of laboratory facilities. H. Atkinson would like to acknowledge the University of Leicester for sabbatical leave.

References

1. Spencer DB, Mehrabian R, Flemings MC (1972) *Metall Trans* 3:1925. doi:10.1007/BF02642580
2. Flemings MC (1991) *Metall Trans* A22:957
3. Kirkwood DH (1994) *Int Mater Rev* 39:173
4. de Figuredo A (ed) (2001) *Science and technology of semi-solid processing*. North American Die Casting Association, Rosemont, IL
5. Fan Z (2002) *Int Mater Rev* 47:49. doi:10.1179/095066001225001076
6. Atkinson HV (2005) *Prog Mater Sci* 50:341. doi:10.1016/j.pmatsci.2004.04.003
7. Kaneuchi T, Shibata R, Ozawa M (2002) In: Tsutsui Y, Kiuchi M, Ichikawa K (eds) *Proceedings of the 7th international conference on advanced semi-solid processing of alloys and composites*, Tsukuba, Japan, 2002. National Institute of Advanced Science and Technology and the Japan Society for Technology of Plasticity, p 145
8. Mitsuru A, Hiroto S, Yasunori H, Tatsuo S, Satoru S, Atsushi Y (1996) *Method and apparatus for shaping semisolid metals*, UBE Industries Limited, Patent EP 0745694 A1
9. Hall K, Kaufmann H, Mundl A (2000) In: Chiarmetta GL, Rosso M (eds) *Proceedings of the 6th international conference on semi-solid processing of alloys and composites*, Turin, Italy, 2000. Edimet Spa, Brescia, Italy, p 23
10. Kaufmann H, Ranshofen H, Wabusseg H, Uggowitzner PJ (2000) *Aluminium* 76:70
11. Kaufmann H, Mundl A, Uggowitzner PJ, Potzinger R, Ishibashi N (2002) *Die Cast Eng* 4:16
12. Uggowitzner PJ, Kaufmann H (2004) *Steel Res Int* 75:525
13. Zhu MF, Kim JM, Hong CP (2001) *ISIJ Intern* 41:992. doi:10.2355/isijinternational.41.992
14. Jackson KA, Hunt JD (1965) *Acta Metall* 13:1212. doi:10.1016/0001-6160(65)90061-1
15. Beckerman C, Wang CY (1996) *Metall Mater Trans* 27A:2784. doi:10.1007/BF02652371
16. Hansen G, Hellawell A, Lu SZ, Steube RS (1996) *Metall Mater Trans* 27A:569. doi:10.1007/BF02648947
17. Christenson MS, Incropera FP (1989) *Int J Heat Mass Transfer* 32:47. doi:10.1016/0017-9310(89)90090-2
18. Prescott PJ, Incropera FJ (1996) *Transp Phenom Mater Process* 28:231
19. Paradies CJ, Kim GT, Glicksman ME, Smith RN (1993) In: Pionka TS, Voller V, Katgerman L (eds) *Proceedings of the international congress modelling of casting, welding and advanced solidification processes VI*, TMS, pp 309–316
20. Chen F (2001) *Proc Natl Sci Counc ROCA* 25(2):71
21. Paradies CJ, Smith RN, Glicksman ME (1997) *Metall Mater Trans* 28A:875
22. Mullis AM, Battersby SE, Fletcher HL (1998) *Scr Mater* 39:147. doi:10.1016/S1359-6462(98)00143-2
23. Kaneko K, Koyaguchi T (2000) *J Vulcanol Geotherm Res* 96:161. doi:10.1016/S0377-0273(99)00145-6
24. Wang GX, Yao C, Chung BTF (1999) *Proc ASME Heat Transfer Division* 364-2:281
25. Appolaire B, Albert V, Combeau H, Lesoult G (1998) *Acta Mater* 46:5851. doi:10.1016/S1359-6454(98)00236-5
26. Cardoso Legoretta E, Atkinson HV, Jones H (submitted) *J Mater Sci*. doi:10.1007/s10853-008-2829-1